

(12) INTERNATIONAL APPLICATION PUBLISHED UNDER THE PATENT COOPERATION TREATY (PCT)

(19) World Intellectual Property Organization
International Bureau



(43) International Publication Date
26 September 2002 (26.09.2002)

PCT

(10) International Publication Number
WO 02/075107 A1

BEST AVAILABLE COPY

- (51) International Patent Classification⁷: **E21B 43/10, 41/00**
- (21) International Application Number: **PCT/GB02/01315**
- (22) International Filing Date: **20 March 2002 (20.03.2002)**
- (25) Filing Language: **English**
- (26) Publication Language: **English**
- (30) Priority Data:
0106820.4 20 March 2001 (20.03.2001) **GB**
- (71) Applicant (for all designated States except US): **WEATHERFORD/LAMB, INC.** [US/US]; 515 Post Oak Blvd, Suite 600, Houston, Tx Texas 77027 (US).
- (72) Inventors; and
- (75) Inventors/Applicants (for US only): **SIMPSON, Neil, Andrew, Abercrombie** [GB/GB]; Burn of Daff Farm, Downies, Portlethen, Aberdeen AB12 4QX (GB).
- (54) Title: **TUBING SEAL**

MACKAY, Alexander, Craig [GB/GB]; 13 Skene Square, Aberdeen AB25 2UU (GB).

(74) Agents: **MCCALLUM, William, Potter et al.**; Cruikshank & Fairweather, 19 Royal Exchange Square, Glasgow G1 3AE (GB).

(81) Designated States (national): **AE, AG, AL, AM, AT, AU, AZ, BA, BB, BG, BR, BY, BZ, CA, CH, CN, CO, CR, CU, CZ, DE, DK, DM, DZ, EC, EE, ES, FI, GB, GD, GE, GI, GM, HR, HU, ID, IL, IN, IS, JP, KE, KG, KP, KR, KZ, LC, LK, LR, LS, LT, LU, LV, MA, MD, MG, MK, MN, MW, MX, MZ, NO, NZ, OM, PH, PL, PT, RO, RU, SD, SE, SG, SI, SK, SL, TJ, TM, TN, TR, TT, TZ, UA, UG, US, UZ, VN, YU, ZA, ZM, ZW.**

(84) Designated States (regional): **ARIPO patent (GH, GM, KE, LS, MW, MZ, SD, SL, SZ, TZ, UG, ZM, ZW), Eurasian patent (AM, AZ, BY, KG, KZ, MD, RU, TJ, TM), European patent (AT, BE, CH, CY, DE, DK, ES, FI, FR, GB, GR, IE, IT, LU, MC, NL, PT, SE, TR), OAPI patent (BF, BJ, CF, CG, CI, CM, GA, GN, GQ, GW, ML, MR, NE, SN, TD, TG).**

[Continued on next page]



WO 02/075107 A1

BROAD FORMED GROOVE

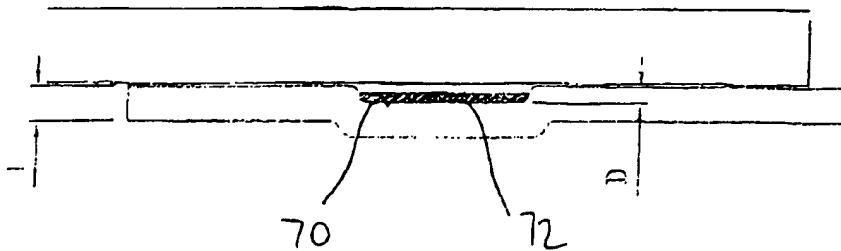

(57) Abstract: A method of forming a seal between two tubular members (30, 32) comprises providing a first tubular member (30) having an internal surface and an external surface describing a first diameter, with a recess (34) in the external surface at a seal portion of the first tubular member. A deformable circumferentially extending sealing member (36) is located in the recess, the sealing member describing an external diameter no greater than the first diameter. The first tubular member (30) is located within a second tubular member (32) and the seal portion of the first tubular member (30) is expanded such that the sealing member (36) engages an inner surface of the second tubular member (32).



Published:

— with international search report

For two-letter codes and other abbreviations, refer to the "Guidance Notes on Codes and Abbreviations" appearing at the beginning of each regular issue of the PCT Gazette.

TUBING SEAL

Aspects of this invention relate to a tubing seal, and in particular to a method and arrangement for producing a seal between two tubing sections. Other aspects of the invention relate to a tubing anchor, and to a method and arrangement for anchoring one tubing section relative to another. The different aspects of the invention have particular utility in downhole applications.

In many instances it is desired to provide a seal between two overlapping tubing sections in a downhole environment. Where space permits, the seals may be formed of elastomeric packer elements or perhaps as metal-to-metal seals which are energised by spring packs or the like. However, in many applications there will not be sufficient space to accommodate such a sealing arrangement, for example in thin-wall tubing, and in such cases the seals are more often provided in the form of O-ring or chevron sealing members. It has also been proposed to create seals around expandable tubing using sealing members in the form of bands of relatively soft metal, as described in PCT/GB99/04365. In such cases, in order to create an effective seal, it is necessary for the sealing member to extend beyond the surface of the tubing. This makes the seal vulnerable to damage and dislodgement as the tubing is run into the bore.

It is among the objectives of aspects of the present invention to provide a method of forming a seal which obviates or mitigates these and other disadvantages of the prior art.

In other instances it is desired to anchor or secure

one tubing section or tool relative to another. This is often achieved by means of slips, typically fingers or keys having a serrated or grooved outer face which co-operate with wedges or cams to push the slips radially outwards to engage with surrounding casing. However, such slips, and the associated slip energising or setting arrangement, occupy a relatively large volume. As described in applicant's International (PCT) Application No PCT/GB9904365, it has been proposed to overcome this difficulty in some situations by providing a hanger arrangement in which inner tubing carrying small hard elements on its outer surface is expanded into engagement with surrounding tubing. However, the gripping elements are exposed to damage as the inner tubing is run into the bore and may, for example, be scraped from the tubing by contact with a ledge or other restriction. Also, the relatively hard elements may score or scrape the relatively soft material of the existing casing, or bore restrictions such as valve seats, as the tubing is run in.

It is among the objects of other aspects of the invention to provide an anchoring arrangement which obviates or mitigates these disadvantages.

According to a first aspect of the present invention there is provided a method of forming a seal between two tubular members, the method comprising:

providing a first tubular member having an internal surface and an external surface, the external surface describing a first diameter;

providing at least one recess in said external surface at a seal portion of the first tubular member while retaining the wall thickness of the tubular member;

locating a deformable sealing member in the recess such that the sealing member describes an external diameter no greater than said first diameter;

5 locating the first tubular member within a second tubular member; and

expanding at least the seal portion of the first tubular member such that the sealing member engages an inner surface of the second tubular member.

10 According to another aspect of the present invention there is provided a seal-forming arrangement comprising:

a first tubular member having an internal surface, and an external surface describing a first diameter, the tubular member defining at least one recess in said external surface at a deformable seal portion of the first tubular member, said seal portion having a wall thickness
15 substantially equal to the wall thickness of the tubular member adjacent said seal portion; and

a deformable sealing member in the recess, the sealing member describing an external diameter no greater than said
20 first diameter,

wherein expansion of at least the seal portion of the first tubular member increases the diameter of the sealing member to at least said first diameter.

25 Preferably, the sealing member initially describes a diameter less than said first diameter, that is the outer surface of the sealing member is recessed from the exterior of the tubular member.

30 According to another aspect of the present invention there is provided a method of forming a seal between two tubular members, the method comprising:

providing a first tubular member having an internal

surface and an external surface describing a first diameter;

providing at least one recess in said external surface at a seal portion of the first tubular member;

5 locating a deformable circumferentially extending sealing member in the recess and such that the sealing member describes an external diameter no greater than said first diameter;

10 locating the first tubular member within a second tubular member; and

expanding at least the seal portion of the first tubular member such that the sealing member engages an inner surface of the second tubular member.

15 According to a further aspect of the present invention there is provided a seal-forming arrangement comprising:

a first tubular member having an internal surface, and an external surface of a first diameter, the tubular member defining at least one recess in said external surface at a deformable seal portion of the first tubular member; and

20 a deformable sealing member in the recess, the sealing member describing an external diameter no greater than said first diameter,

25 wherein expansion of at least the seal portion of the first tubular member increases the diameter of the sealing member to at least said first diameter.

30 As the sealing member is located within the recess, and does not initially extend beyond the external surface of the first tubular member, the sealing member is protected from damage during handling and running into the second tubular member. This is particularly useful in downhole applications, in which the first tubular member

may have to pass through several thousand metres of tubing defining ledges, restrictions and other hazards, before reaching the sealing location.

Where reference is made to a second tubular member, this is intended to encompass any appropriate tubing or bore, including a bore formed in a non-cylindrical object, and a drilled bore in an earth formation.

The recess may take any appropriate form, and preferably will be in the form of an annular or part-annular depression. Alternatively, adjacent surface portions of the first tubular member may be upset, or may define ribs or other projections to protect the sealing member.

The recess may be formed by one or more of a variety of methods, including: deforming the first tubular member at said seal portion to create a localised reduction in external diameter, which may occur while retaining the wall thickness of the tubular member; or moving or removing material from said seal location to create a region of reduced wall thickness. Alternatively, the tubular member may be cast or otherwise formed with the recess.

The sealing member receiving recess may itself be provided within a larger recess. This provides still further protection for the sealing member; for example, fluid flowing in an annulus between the first and second tubular members will decelerate on encountering the larger recess, and thus there is less likelihood of the sealing member being washed out of the recess.

The sealing member may be formed of any appropriate material, including an elastomer or a metal, which metal may be relatively ductile or, alternatively, may be adapted

to experience only elastic deformation in the creation of a sealing contact with the second tubing member.

On expanding the seal portion, the sealing member may be deformed to a lens-shaped cross-section.

5 Preferably, the seal portion is expanded by rolling expansion, with an expansion member being rotated within the first tubular member with a face in rolling contact with an internal surface thereof. Such expansion creates a hoop stress in the first tubular member, which tends to
10 increase the ability of the member to withstand external compressive or crush forces, including external fluid pressure. Most preferably, the seal portion is deformed by compressive plastic deformation, which may produce a
15 localised reduction in wall thickness and a subsequent increase in diameter.

 The first tubular member may be expanded only at or in the area of the seal portion, or an extended portion of the tubular member may be expanded; this may be useful in anchoring the first tubular member in the second tubular
20 member.

 Preferably, a plurality of longitudinally spaced-apart circumferential seal members are provided.

 Another aspect of the present invention relates to a method of forming a coupling or anchor between two tubular
25 members, the method comprising:

 providing a first tubular member having an internal surface and an external surface describing a first diameter;

 providing at least one recess in said external surface
30 at an anchor portion of the first tubular member;

 locating an anchoring member in the recess, the

anchoring member describing an external diameter no greater than said first diameter;

locating the first tubular member within a second tubular member; and

5 expanding at least the anchor portion of the first tubular member such that the anchoring member engages an inner surface of the second tubular member.

According to another aspect of the present invention there is provided an anchor-forming arrangement comprising:

10 a first tubular member having an internal surface, and an external surface of a first diameter, the tubular member defining at least one recess in said external surface at a deformable anchor portion of the first tubular member; and

 an anchoring member in the recess, the anchoring member describing an external diameter no greater than said first diameter,

 wherein expansion of at least the anchor portion of the first tubular member increases the diameter of the anchoring member to at least said first diameter.

20 As the anchoring member is located within the recess, and does not initially extend beyond the external surface of the first tubular member, the anchoring member is protected from damage during handling and running into the second tubular member and will itself not cause damage to the second tubular member.

 The anchoring member may be formed of any appropriate material, and typically is formed of a relatively hard material, that is a material harder than the material of the tubular member. The anchoring member may take any appropriate form, and is preferably in the form of a ring, which may be split or otherwise segmented. The member may

30

define serrations or teeth. Alternatively, the anchoring member may be in the form of a volume or area of hard material, or an area of blocks or pieces of relatively hard material.

5 The anchoring member may be releasable, that is the member may be movable to disengage from the an inner surface of the second tubular member. This may be achieved by moving the engaged anchor member relative to the second tubular member to locate the anchor member above a groove
10 or the like, or by otherwise removing support for the anchor member.

 The invention also relates to a method of reinforcing a thin-walled tubular member against crush forces, the method comprising:

15 locating a thin-walled first tubular member within a larger diameter second tubular member; and

 expanding the first tubular member by rolling expansion to create a hoop stress in the member and to bring an outer surface of the first member into contact
20 with the second member,

 whereby subsequent collapse of the first member requires circumferential compression of the wall of the first member or deformation of the second member.

 This aspect of the invention allows relatively thin
25 walled tubing to be utilised as, for example, a patch or straddle in circumstances where the tubing, before expansion, would not be capable of resisting the external pressure forces which the expanded tubing will experience. This allows use of thinner wall and thus less expensive
30 tubing, and also facilitates expansion of the tubing.

 These and other aspects of the present invention will

now be described, by way of example only, with reference to the accompanying drawings, in which:

Figure 1 is a diagrammatic sectional view of portions of the walls of two tubing members of a seal-forming arrangement in accordance with an embodiment of the present invention, prior to expansion of the inner tubing member.

Figure 2 corresponds to Figure 1, but shows the tubing walls after expansion of the inner tubing member;

Figures 3a, 3b and 3c illustrate steps in the creation of a seal in accordance with an embodiment of the present invention and utilising the seal forming arrangement of Figure 1;

Figures 4 and 5, 6 and 7, 8 and 9, 10 and 11, and 12 and 13, are diagrammatic sectional views of portions of the walls of tubing members of seal forming arrangements in accordance with further embodiments of the present invention, shown prior to and following expansion of the inner tubing member, respectively;

Figure 14 is a diagrammatic sectional view of portions of the walls of tubing members of a tubing coupling arrangement in accordance with an embodiment of a further aspect of the present invention, prior to expansion of the inner tubing member;

Figure 15 corresponds to Figure 14, but shows the tubing walls after expansion of the inner tubing member;

Figures 16a, 16b and 16c illustrate the expansion of the inner tubing member of Figure 14;

Figures 17a, 17b and 17c illustrate an alternative expansion process for the inner tubing member of Figure 14;

Figures 18 and 19 are diagrammatic sectional views of portions of the walls of tubing members of a tubing

coupling arrangement in accordance with another embodiment of the present invention, shown prior to and following expansion of the inner tubing member, respectively;

5 Figure 20 is a diagrammatic sectional view of portions of the walls of two tubing members of a coupling arrangement in accordance with a still further embodiment of the present invention, prior to expansion of the inner tubing member;

10 Figure 21 corresponds to Figure 20, but shows the tubing walls after expansion of the inner tubing member;

Figures 22a and 22b show steps in the creation of the coupling arrangement of Figure 21;

15 Figure 23 is a diagrammatic sectional view of portions of the walls of two tubing members of a coupling arrangement in accordance with another embodiment of the present invention, prior to expansion of the inner tubing member;

Figure 24 corresponds to Figure 23, but shows the tubing walls after expansion of the inner tubing member;

20 Figures 25a and 25b show steps in the release of the coupling arrangement of Figure 24;

25 Figure 26 is a diagrammatic sectional view of portions of the walls of two tubing members of a coupling arrangement in accordance with yet another embodiment of the present invention, prior to expansion of the inner tubing member;

Figure 27 corresponds to Figure 26, but shows the tubing walls after expansion of the inner tubing member;

30 Figures 28a and 28b show steps in the release of the coupling arrangement of Figure 27; and

Figures 29, 30 and 31 are perspective, side and

sectional views of an inner tubing member of a coupling arrangement in accordance with a still further embodiment of the present invention.

Reference is first made to Figure 1 of the drawings, which illustrates parts of portions of the walls of first and second tubular members 30, 32 of a seal-forming arrangement in accordance with an embodiment of the present invention. The larger diameter outer second tubing member 32 may be located downhole in the form of, for example, metal bore-lining casing. The inner first tubing member 30 may be part of a packer or the upper end of a section of bore-lining casing or liner which is to be sealed relative to the second tubing member 32, as will be described.

Machined in an outer face of the first tubing member 30 is an annular groove 34, which groove is occupied by a sealing member in the form of an elastomeric sealing ring 36. The outer surface of the sealing ring 36 has a maximum diameter which is less than the adjacent portions of the tubing member 30.

To form a seal between the tubing members 30, 32, the first tubing member 30 is expanded by a rolling expansion process which reduces the thickness of the wall of the first tubing member from T to t , as illustrated in Figure 2, and further decreases the depth of the groove 34 from D to d . The reduction in depth of the groove 34, which results in the groove 34 being shallower than the sealing ring 36, urges the sealing ring 36 radially outwards relative to the outer surface of the tubing member 30 and into sealing contact with the inner surface of the second tubing member 32.

Reference is now made to Figures 3a, 3b and 3c of the

drawings, which illustrate the expansion of the inner tubing member 30. The Figures illustrate an expansion device 38 including a body 40 carrying three piston-mounted rollers 42. The device 38 is mounted on an appropriate running string (not shown) and by supplying pressurised fluid to the interior of the body 40 the rollers 42 are urged radially outwards and into contact with the inner wall of the first tubing member 30. If the device 38 is rotated and axially advanced, the rollers 42 reduce the wall thickness of the tubing member 30, and thereby increase the diameter of the member 30. Thus, the sealing arrangement as illustrated in Figure 2 may be formed.

Figures 4 and 5 of the drawings illustrate an arrangement in which the groove 50 which receives the sealing ring 52, in the form of an elastomer O-ring, is formed in the first tubing member 54, while retaining the wall thickness at the seal portion 56 of the member 54, in contrast to the reduction in wall thickness which occurs when the groove is machined, as illustrated in Figure 1 above.

As will be noted from Figure 4, forming the groove in the tubing member 54 creates an inner shoulder or protrusion 58, however following expansion of the tubing member 54, utilising a similar method as that illustrated in Figures 3a, 3b and 3c, the member 54 presents a smooth inner surface. In this example, the sealing ring 52 is illustrated as initially being in the form of an O-ring which, following expansion of the first tubing member 54, is deformed to a lens shape 60, occupying a shallow depression of corresponding shape 61. The configuration of the deformed sealing ring 60 provides for a large contact

area with both the outer surface of the first tubing member 54 and the inner surface of the outer second tubing member 62. Further, the area of the deformed seal 60 exposed to pressurised fluid attempting to pass between the tubing members 54, 62 is relatively small, such that the pressure forces acting on the sleeves 60 will also be relatively small.

Reference is now made to Figure 6 and 7 of the drawings, which show an alternative groove and sealing member configuration, in particular the formed groove 70 being relatively broad, and the sealing member 72 having a corresponding axial extent, and being relatively shallow such that the outer face of the sealing member 72 lies below the outer surface of the first tubing member.

Figures 8 and 9 of the drawings illustrate an arrangement in which a sealing member 80 is located in a machined narrow groove 82 itself formed in the middle of a machined broad groove 84, this configuration offering additional protection for the sealing member 80 while the first tubing member 86 is being run into the bore.

In the arrangement illustrated in Figures 10 and 11, a sealing member 90 is located in a machined narrow groove 92 itself located centrally within a relatively broad formed groove 94.

In Figures 12 and 13, a sealing member 100 is located in a formed narrow groove 102 itself located centrally within a formed broad groove 104.

It will be noted by comparing the different forms of groove arrangements that the use of formed grooves tends to result in a greater degree of deformation of the sealing member. Thus, the form of the groove and the form of the

sealing member may be varied according to the intended application.

Reference is now made to Figures 14 and 15 of the drawings, which illustrate portions of the wall of first and second tubing members 110 and 112 of a coupling arrangement in accordance with an embodiment of the further aspect of the present invention. In this embodiment a ring slip member 114 having a toothed outer face is located in a machined groove 116 located centrally within a relatively broad formed groove 118. As will be described, if the first tubing member 110 is expanded by rolling expansion, the thickness of the first tubing member 110 is reduced from T to t , with a corresponding increase in diameter, the formed groove 118 is "removed", and the depth of the machined groove 116 relative to the adjacent outer surface of the first tubing member 110 is reduced from D to d .

One example of the expansion process is illustrated in Figure 16, and utilises an expansion device 38 similar to the device described above with reference Figures 3a, 3b and 3c. The expansion process is illustrated in 16a, 16b and 16c, and involves rotation and axial advancement of the energised expansion device 38. Following expansion of the first tubing member 110, the teeth on the outer surface of the ring slip member 114 engage the inner face of the second tubing member 112, as illustrated in Figure 15.

A slightly different expansion operation is illustrated in Figure 17a, 17b and 17c of the drawings, however in this case the degree of expansion is selected such that the broad formed groove 118 is retained in the expanded first tubing member 120, although the groove 122 is of decreased depth with respect to the original groove

in the unexpanded member.

Figures 18 and 19 illustrate an alternative anchoring or coupling arrangement, in which a ring slip member 124 is located in a relatively narrow machined groove 126.

5 Reference is now made to Figures 20, 21 and 22a and 22b, which show a further alternative arrangement in which a ring slip member 130 is located in a narrow machined groove 132 positioned centrally within a broader formed groove 134. In addition, substantially conventional O-ring
10 seals 136, 137 are located above and below the groove 134 and provide a seal between the outer surface of the first tubing member 138 and the inner surface of the second tubing member 140. Also, a fluid communicating passage 142 extends between the internal bore of the first tubing
15 member 138 and the groove 134.

To engage the ring slip member 130 with the second tubing member 140, and lock the first tubing member 138 relative the second tubing member 140, an expander is passed through the first tubing member 138 to "take out"
20 the protrusion 144 created in forming the groove 134. After expansion, and as illustrated in Figure 21, a slightly shallower groove 146 is retained in the expanded tubing.

To subsequently release the first tubing member 138
25 from the second tubing member 140, a tool 148 is run into the bore to provide fluid communications between the tool interior 150 and the fluid port 142, as illustrated in Figure 22a. If pressurised fluid is then supplied through the tool 148 and into the groove 146, the tubing wall
30 around the ring slip member 130 may be plastically deformed to such an extent that the ring slip member 130 is moved

radially inwards, out of engagement with the inner surface of the second tubing member 140, as illustrated in Figure 22b.

Reference is now made to Figures 23, 24 and 25 of the drawings, which are a diagrammatic sectional views of portions of the walls of two tubing members 156, 158 of a coupling arrangement in accordance with another embodiment of the present invention. In this embodiment, a ring slip member 160 is located in a machined groove 162 in the inner tubing member 156, the groove having a shallow portion 162a and a deeper portion 162b. The slip member 160 is initially located in the shallow groove portion 162a, and is retained there by a shear pin 164.

The ring slip member 160 is engaged with the outer tubing 158, to lock the tubing members 156, 158 together, in a similar manner to the above described embodiments, that is by passing an expander through the inner tubing member 156. The ring slip 160 may or may not be split, however during the locking process the slip member 160 is not deformed completely past the yield point of the material; this provides a restoring force to facilitate release of the member 160, as described below.

To release the inner tubing member 156, an upwards force is applied to the inner tubing member 156, which force may be applied mechanically or hydraulically. The release force must be sufficient to shear the pin 164, allowing the tubing 156 to move upwards relative to the outer tubing 158 and the slip member 160, which is of course locked relative to the tubing 158. This relative movement positions the slip member 160 in the deeper portion of the groove 162b (Figure 25a), and subsequent

movement of the tubing 156, combined with the restoring force within the elastically deformed member 160, moves the slip member radially inwardly and into the deeper slot portion 162b (Figure 25b), thus releasing the tubing 156
5 such that it may be withdrawn or otherwise moved in the bore.

Reference is now made to Figures 26 to 28 of the drawings, which are diagrammatic sectional views of portions of the walls of two tubing members 170, 172 of
10 another releasable coupling arrangement. The arrangement differs from that of Figures 23 to 25 in that the ring slip member 174 features a tapering profile, as does the machined groove 176 in which the slip member 174 is located. The setting and release procedures are the same
15 as for the embodiment of Figures 23 to 25, however load is supported against the interference of the slip member 174 compressively on the tapered groove profile, as opposed to on the upper face or flank of the slip member

Reference is now made to Figures 29, 30 and 31, which
20 illustrate tubing 260 forming part of a hanger system in accordance with an embodiment of the invention. The tubing 260 defines two circumferential grooves 262, 263 which accommodate resilient sealing members (not shown). Further, the tubing 260 defines a number of formed recesses
25 which accommodate generally circular slip areas 264 formed of small blocks of relatively hard material held in a softer matrix.

When the tubing 260 is located within a larger diameter tubing (not shown), and expanded as described
30 above, the sealing members in the grooves 262, 263 form seals with the outer tubing, and the blocks of material in the slip areas 264 key into this surrounding larger

diameter tubing. Thus, the expanded tubing 260 is sealed and anchored within the larger diameter tubing.

5 It will be apparent to those of skill in the art that the above-described embodiments provide relatively simple yet effective means for sealing and anchoring a thin wall tubing member within a larger diameter tubing. Further, the provision of one or both of an anchor and a seal may be achieved without any significant loss of diameter, and the arrangement of seals and slip members is such that the
10 seals and slip members are protected from damage while running in and are thus more likely to provide an effective sealing and anchoring arrangement.

15 It will further be apparent to those of skill in the art that the above-described embodiments are merely exemplary of the present invention, and that various modifications may be made thereto without departing from the present invention. For example, the invention is not limited to use in thin wall tubing, and may be utilised in any deformable tubing. Further, the deformable tubing may
20 form part of a larger tubing member which is otherwise non-deformable, or not intended for deformation.

CLAIMS

1. A method of forming a seal between two tubular members, the method comprising:

5 providing a first tubular member having an internal surface and an external surface, the external surface describing a first diameter;

providing at least one recess in said external surface at a seal portion of the first tubular member while retaining the wall thickness of the tubular member;

10 locating a deformable sealing member in the recess such that the sealing member describes an external diameter no greater than said first diameter;

locating the first tubular member within a second tubular member; and

15 expanding at least the seal portion of the first tubular member such that the sealing member engages an inner surface of the second tubular member.

2. The method of claim 1, wherein the second tubular member is located downhole.

20 3. The method of claim 1 or 2, wherein the sealing member initially describes a diameter less than said first diameter.

4. The method of any of claims 1 to 3, wherein the recess is provided in the form of an annular depression.

25 5. The method of claim 4, wherein the annular depression

is formed at least in part by deforming the first tubular member at said seal portion to create a localised reduction in external diameter.

5 6. The method of any of the preceding claims wherein the sealing member receiving recess is provided within a larger recess.

7. The method of any of the preceding claims, wherein on expanding the seal portion, the seal member is deformed to assume a lens-shaped cross-section.

10 8. The method of any of the preceding claims, wherein the seal portion is expanded by rolling expansion, with an expansion member being rotated within the first tubular member with a face in rolling contact with an internal surface thereof.

15 9. The method of claim 8, wherein the seal portion is deformed by compressive plastic deformation, producing a localised reduction in wall thickness and a subsequent increase in diameter.

20 10. The method of any of the preceding claims, wherein the first tubular member is expanded only at or in the region of the seal portion.

11. The method of any of claims 1 to 9, wherein an extended portion of the tubular member is expanded.

12. The method of any of the preceding claims, wherein a

plurality of longitudinally spaced sealing members are provided at the seal portion of the first tubular member and expanding said seal portion of the first tubular member brings the sealing members into engagement with the inner
5 surface of the second tubular member.

13. The method of any of the preceding claims wherein said first tubular member is thin-walled and the seal portion thereof is expanded by rolling expansion to create a hoop stress in the member and to bring the external surface of
10 the first member into contact with the second member, whereby subsequent collapse of the first member requires circumferential compression of the wall of the first member or deformation of the second member.

14. A seal-forming arrangement comprising:
15 a first tubular member having an internal surface, and an external surface describing a first diameter, the tubular member defining at least one recess in said external surface at a deformable seal portion of the first tubular member, said seal portion having a wall thickness
20 substantially equal to the wall thickness of the tubular member adjacent said seal portion; and
a deformable sealing member in the recess, the sealing member describing an external diameter no greater than said first diameter,
25 wherein expansion of at least the seal portion of the first tubular member increases the diameter of the sealing member to at least said first diameter.

15. The arrangement of claim 14, wherein the first tubular

member is tubing adapted for location downhole.

16. The arrangement of claim 14 or 15, wherein the sealing member initially defines a diameter less than said first diameter.

5 17. The arrangement of claim 14, 15 or 16, wherein the recess is in the form of an annular depression.

18. The arrangement of claim 17, wherein the annular depression is defined by a localised reduction in external diameter of the first tubular member.

10 19. The arrangement of any of claims 14 to 18, wherein the sealing member receiving recess is located within a larger recess.

20. The arrangement of any of claims 14 to 19, wherein the sealing member is of an elastomer.

15 21. The arrangement of any of claims 14 to 19, wherein the sealing member is of a ductile metal.

22. The arrangement of any of claims 14 to 21, wherein a plurality of longitudinally spaced sealing members are provided on the first tubular member.

20 23. A method of forming a seal between two tubular members, the method comprising:

providing a first tubular member having an internal surface and an external surface, the external surface

describing a first diameter;

providing at least one recess in said external surface
at a seal portion of the first tubular member;

5 locating a deformable sealing member in the recess
such that the sealing member describes an external diameter
less than said first diameter;

locating the first tubular member within a second
tubular member; and

10 expanding at least the seal portion of the first
tubular member such that the sealing member engages an
inner surface of the second tubular member.

24. The method of claim 23, wherein the second tubular
member is located downhole.

15 25. The method of claim 23 or 24, wherein the recess is
provided in the form of an annular depression.

26. The method of claim 25, wherein the annular depression
is formed at least in part by deforming the first tubular
member at said seal portion to create a localised reduction
in external diameter.

20 27. The method of claim 26, wherein the deformation of the
first tubular member at said seal portion occurs while
retaining the wall thickness of the tubular member.

25 28. The method of claim 26, wherein the deformation of the
first tubular member at said seal portion is achieved by at
least one of moving or removing material from said seal

location to create a region of reduced wall thickness.

29. The method of any of claims 23 to 28, wherein the sealing member receiving recess is provided within a larger recess.

5 30. The method of any of claims 23 to 29, wherein on expanding the seal portion, the seal member is deformed to assume a lens-shaped cross-section.

10 31. The method of any of claims 23 to 30, wherein the seal portion is expanded by rolling expansion, with an expansion member being rotated within the first tubular member with a face in rolling contact with an internal surface thereof.

15 32. The method of claim 31, wherein the seal portion is deformed by compressive plastic deformation, producing a localised reduction in wall thickness and a subsequent increase in diameter.

33. The method of any of claims 23 to 32, wherein the first tubular member is expanded only at or in the region of the seal portion.

20 34. The method of any of claims 23 to 32, wherein an extended portion of the tubular member is expanded.

35. The method of any of claims 23 to 34, wherein a plurality of longitudinally spaced sealing members are provided at the seal portion of the first tubular member and expanding said seal portion of the first tubular member

brings the sealing members into engagement with the inner surface of the second tubular member.

36. The method of any of claims 23 to 35, wherein said first tubular member is thin-walled and the seal portion thereof is expanded by rolling expansion to create a hoop stress in the member and to bring the external surface of the first member into contact with the second member, whereby subsequent collapse of the first member requires circumferential compression of the wall of the first member or deformation of the second member.

37. A seal-forming arrangement comprising:
a first tubular member having an internal surface, and an external surface describing a first diameter, the tubular member defining at least one recess in said external surface at a deformable seal portion of the first tubular member; and

a deformable sealing member in the recess, the sealing member describing an external diameter less than said first diameter,

wherein expansion of at least the seal portion of the first tubular member increases the diameter of the sealing member to at least said first diameter.

38. The arrangement of claim 37, wherein the first tubular member is tubing adapted for location downhole.

39. The arrangement of claim 37 or 38, wherein the recess is in the form of an annular depression.

40. The arrangement of claim 39, wherein the annular depression is defined by a localised reduction in external diameter of the first tubular member.

5 41. The arrangement of claim 40, wherein the wall thickness of the tubular member is retained at the seal location.

42. The arrangement of claim 40, wherein there is a region of reduced wall thickness at the seal location.

10 43. The arrangement of any of claims 37 to 42, wherein the sealing member receiving recess is located within a larger recess.

44. The arrangement of any of claims 37 to 43, wherein the sealing member is of an elastomer.

15 45. The arrangement of any of claims 37 to 43, wherein the sealing member is of a ductile metal.

46. The arrangement of any of claims 37 to 45, wherein a plurality of longitudinally spaced sealing members are provided on the first tubular member.

20 47. A method of forming a coupling or anchor between two tubular members, the method comprising:

providing a first tubular member having an internal surface and an external surface describing a first diameter;

providing at least one recess in said external surface

at an anchor portion of the first tubular member;

locating an anchoring member in the recess, the anchoring member describing an external diameter no greater than said first diameter;

5 locating the first tubular member within a second tubular member; and

expanding at least the anchor portion of the first tubular member such that the anchoring member engages an inner surface of the second tubular member.

10 48. The method of claim 47, wherein the second tubular member is located downhole.

49. The method of claim 47 or 48, wherein the anchoring member initially describes a diameter less than said first diameter.

15 50. The method of any of claims 47 to 49, wherein the recess is provided in the form of an annular depression.

51. The method of any of claims 47 to 50, wherein the recess is formed at least in part by deforming the first tubular member at said anchor portion to create a localised
20 reduction in external diameter.

52. The method of claim 51, wherein the deformation of the first tubular member at said anchor portion occurs while retaining the wall thickness of the tubular member.

53. The method of claim 51, wherein the deformation of the
25 first tubular member at said anchor portion is achieved by

at least one of moving or removing material from said anchor location to create a region of reduced wall thickness.

54. The method of any of claims 47 to 53, wherein the
5 anchoring member receiving recess is provided within a larger recess.

55. The method of any of claims 47 to 54, wherein the anchor portion is expanded by rolling expansion, with an expansion member being rotated within the first tubular
10 member with a face in rolling contact with an internal surface thereof.

56. The method of claim 55, wherein the anchor portion is deformed by compressive plastic deformation, producing a localised reduction in wall thickness and a subsequent
15 increase in diameter.

57. The method of any of claims 47 to 56, wherein the first tubular member is expanded only at or in the region of the anchor portion.

58. The method of any of claims 47 to 56, wherein an
20 extended portion of the tubular member is expanded.

59. The method of any of claims 47 to 58, wherein a plurality of longitudinally spaced anchoring members are provided at the anchor portion of the first tubular member and expanding said anchor portion of the first tubular
25 member brings the anchoring members into engagement with

the inner surface of the second tubular member.

5 60. The method of any of claims 47 to 59 wherein said first tubular member is thin-walled and the anchor portion thereof is expanded by rolling expansion to create a hoop stress in the member and to bring at least a portion of the external surface of the first member into contact with the second member, whereby subsequent collapse of the first member requires circumferential compression of the wall of the first member or deformation of the second member.

10 61. The method of any of claims 47 to 60, further comprising disengaging the anchoring member from the inner surface of the second tubular member.

15 62. The method of claim 61, wherein said disengagement is achieved by moving the anchoring member relative to the first tubular member.

63. A coupling arrangement comprising:

20 a first tubular member having an internal surface, and an external surface describing a first diameter, the tubular member defining at least one recess in said external surface at a deformable anchor portion of the first tubular member; and

an anchoring sealing member in the recess, the anchoring member describing an external diameter no greater than said first diameter,

25 wherein expansion of at least the anchor portion of the first tubular member increases the diameter described by the anchoring member to at least said first diameter.

64. The arrangement of claim 63, wherein the first tubular member is tubing adapted for location downhole.

5 65. The arrangement of claim 63 or 64, wherein the anchoring member initially defines a diameter less than said first diameter.

66. The arrangement of claim 63, 64 or 65, wherein the recess is in the form of an annular depression.

10 67. The arrangement of any of claims 63 to 66, wherein the recess is defined by a localised reduction in external diameter of the first tubular member.

68. The arrangement of claim 67, wherein wall thickness of the tubular member is retained at the anchor location.

69. The arrangement of claim 67, wherein there is a region of reduced wall thickness at the seal location.

15 70. The arrangement of any of claims 63 to 69, wherein the sealing member receiving recess is located within a larger recess.

20 71. The arrangement of any of claims 63 to 70, wherein the anchoring member is of a relatively hard material.

72. The arrangement of any of claims 63 to 71, wherein the anchoring member is in the form of a ring.

73. The arrangement of any of claims 63 to 71, wherein the

anchoring member is in the form of an area of relatively hard material.

74. The arrangement of any of claims 63 to 73, wherein the anchoring member is arranged to be retractable.

5 75. The arrangement of claim 74, wherein the anchoring member is initially releasably retained in a shallow part of a recess in the external surface of the first tubular member and is movable to a deeper part of said recess.

10 76. The arrangement of any of claims 63 to 75, wherein a plurality of longitudinally spaced anchoring members are provided on the first tubular member.

77. A method of reinforcing a thin-walled tubular member against crush forces, the method comprising:

15 locating a thin-walled first tubular member within a larger diameter second tubular member; and

expanding the first tubular member by rolling expansion to create a hoop stress in the member and to bring an outer surface of the first member into contact with the second member,

20 whereby subsequent collapse of the first member requires circumferential compression of the wall of the first member of deformation of the second member.

MACHINED GROOVE

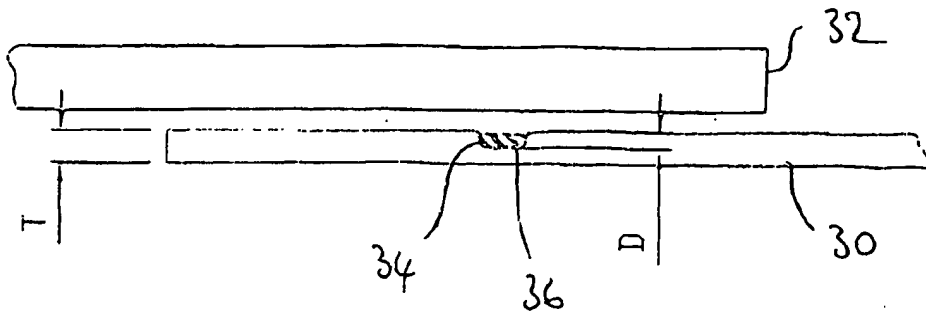

Figure 1

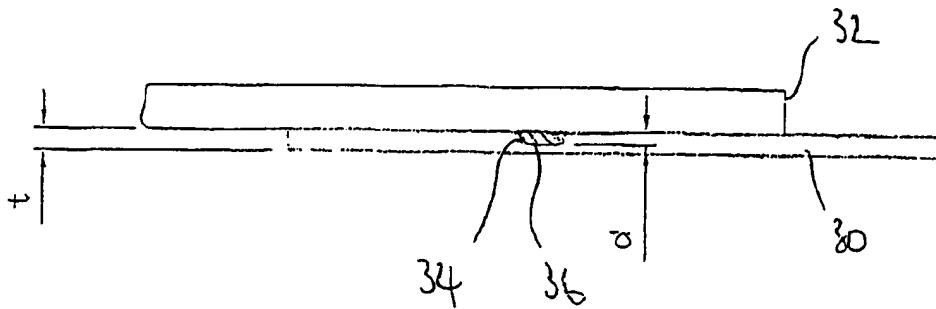

Figure 2

MACHINED NARROW GROOVE

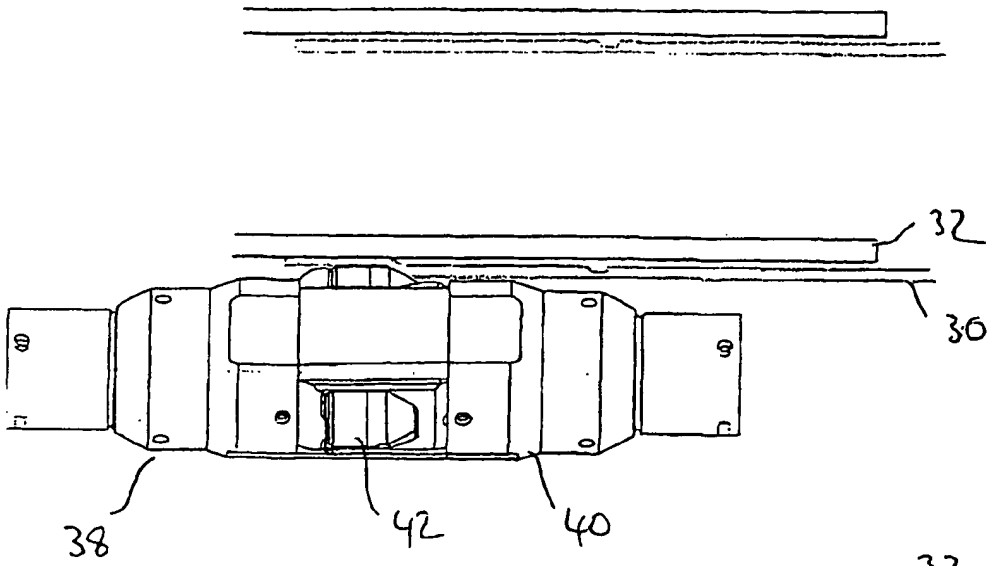

Figure 3a

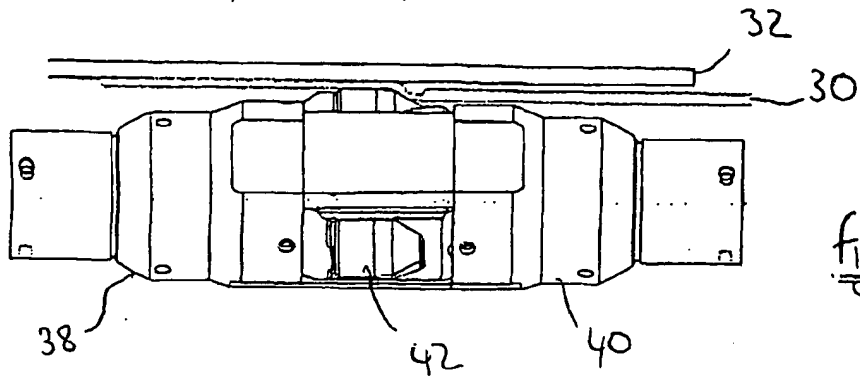

Figure 3b

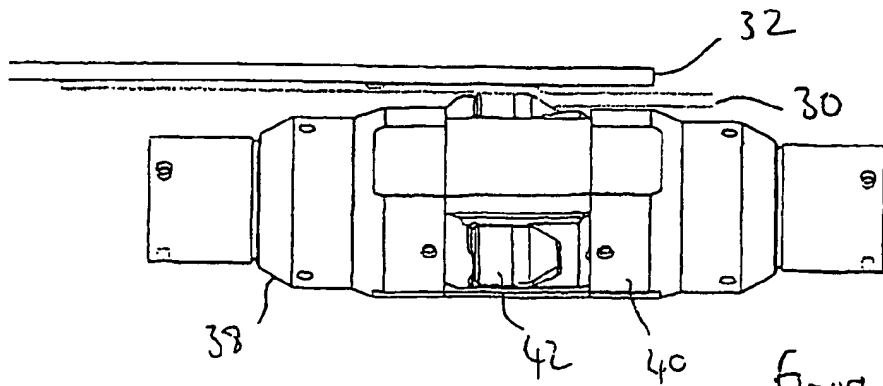
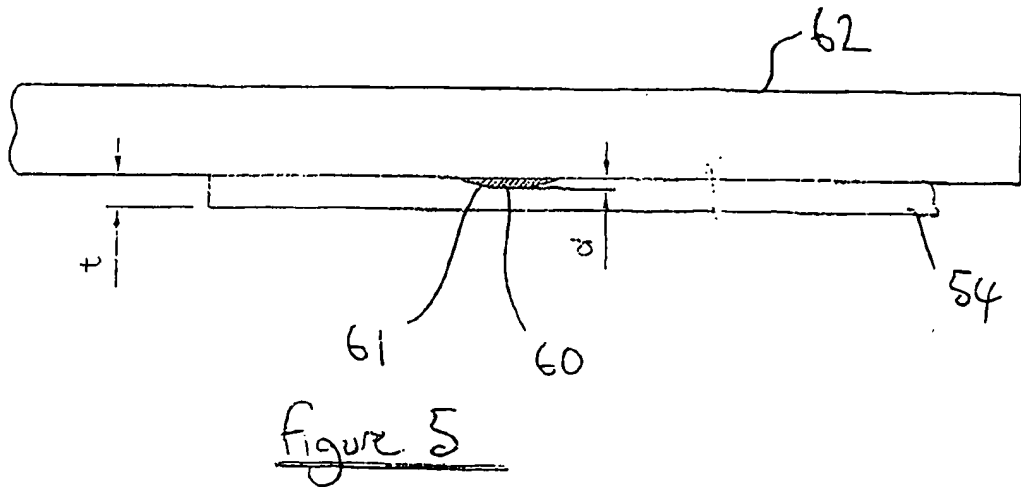
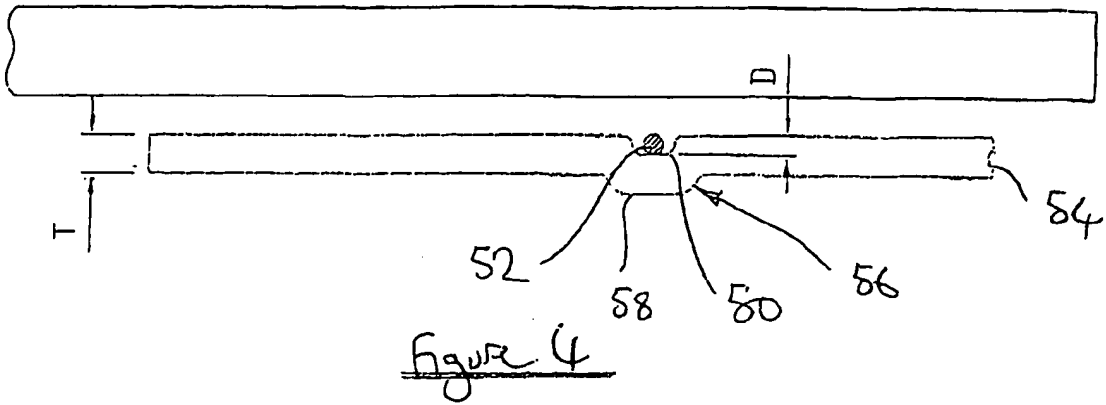

Figure 3c

FORMED NARROW GROOVE



BROAD FORMED GROOVE

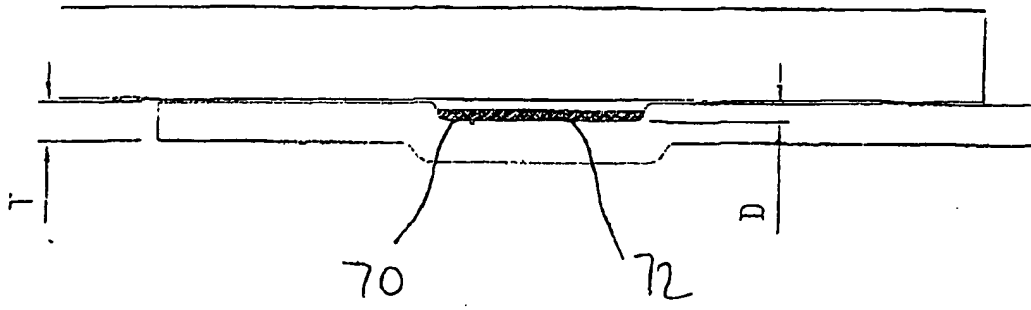

figure 6

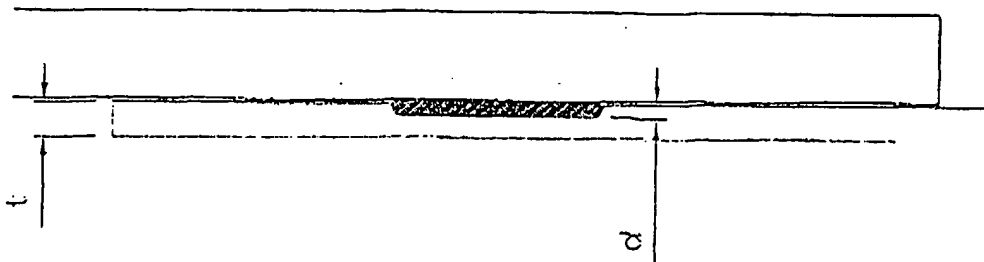

figure 7

MACHINED BROAD GROOVE
WITH MACHINED NARROW GROOVE

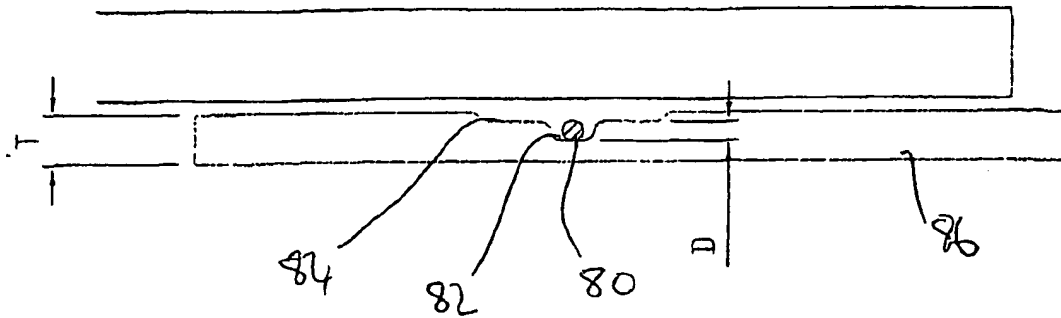

Figure 8

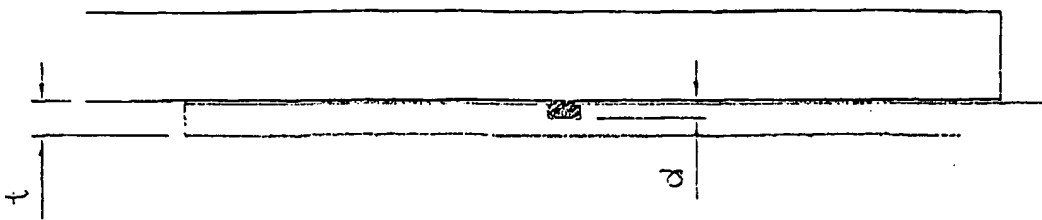

Figure 9

BROAD FORMED GROOVE
WITH MACHINED NARROW GROOVE

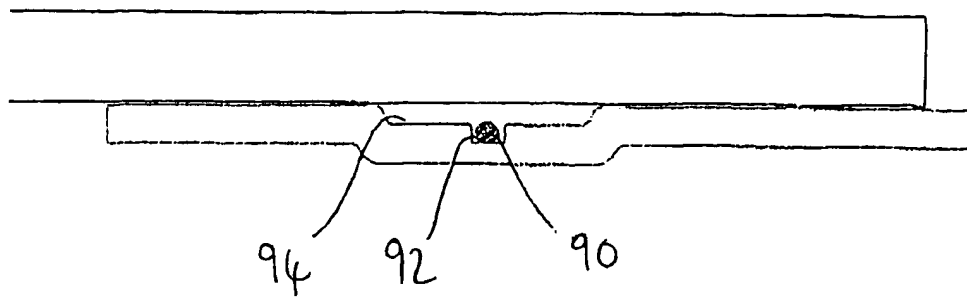

Figure 10

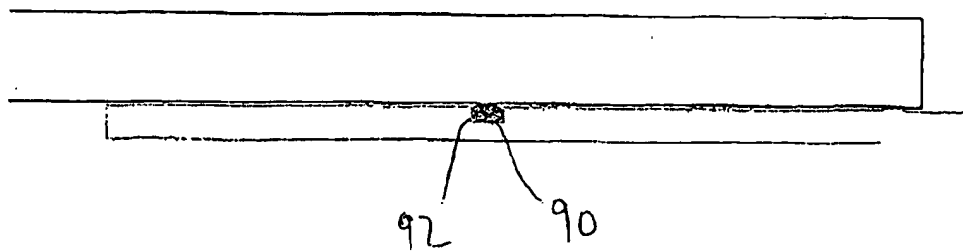

Figure 11

FORMED BROAD GROOVE
WITH FORMED NARROW GROOVE

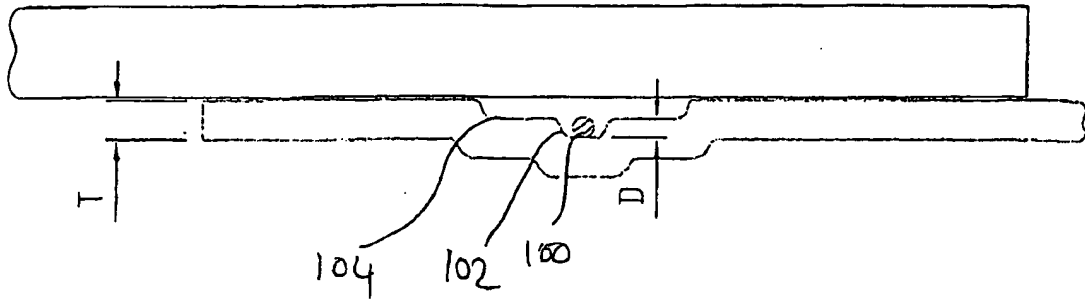

Figure 12

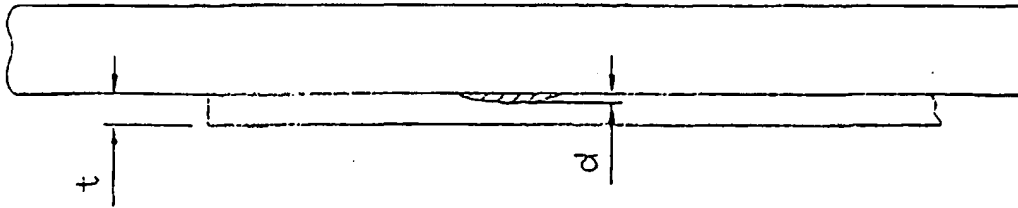

Figure 13

RING SLIP IN BROAD GROOVE

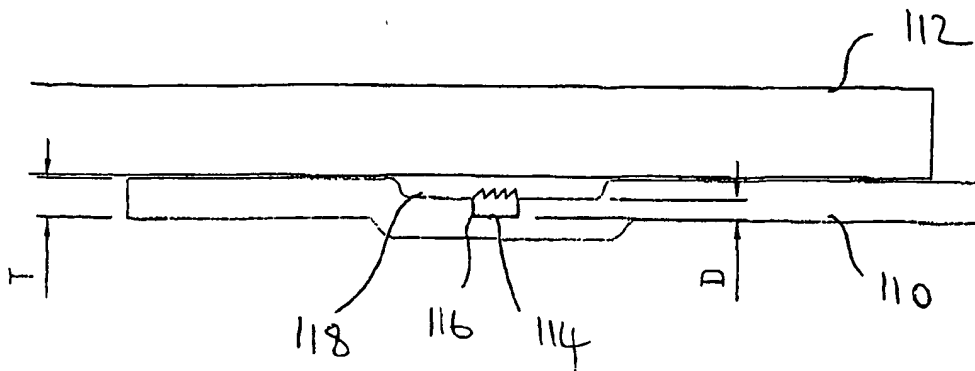

Figure 14

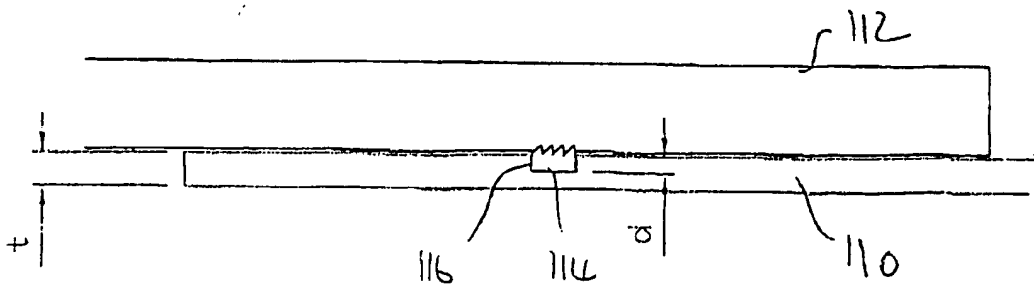

Figure 15

SETTING SEQUENCE
RING SLIP IN BROAD GROOVE
(COMPLETE DEFORMATION)

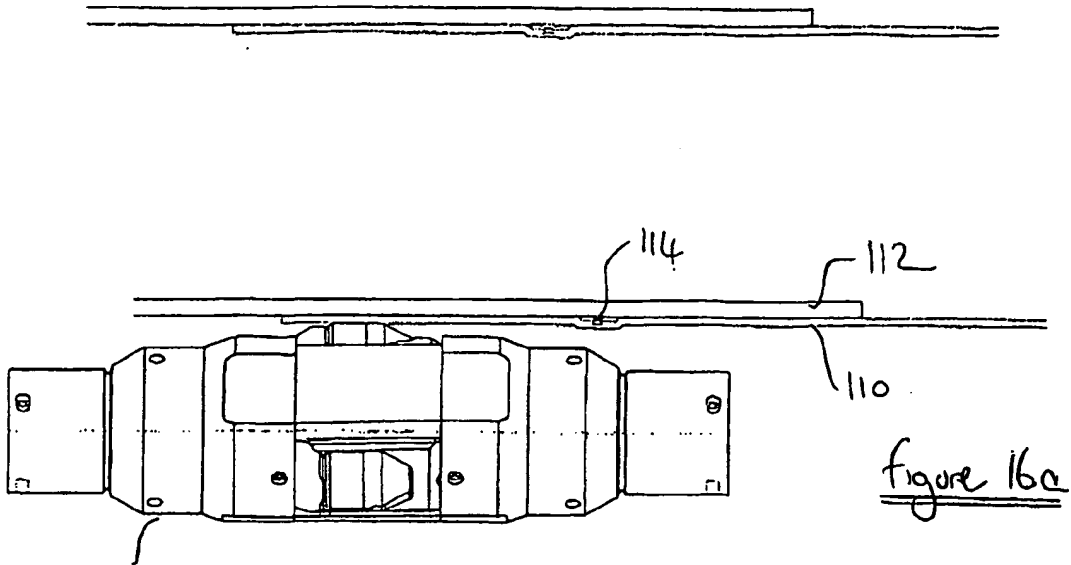

Figure 16a

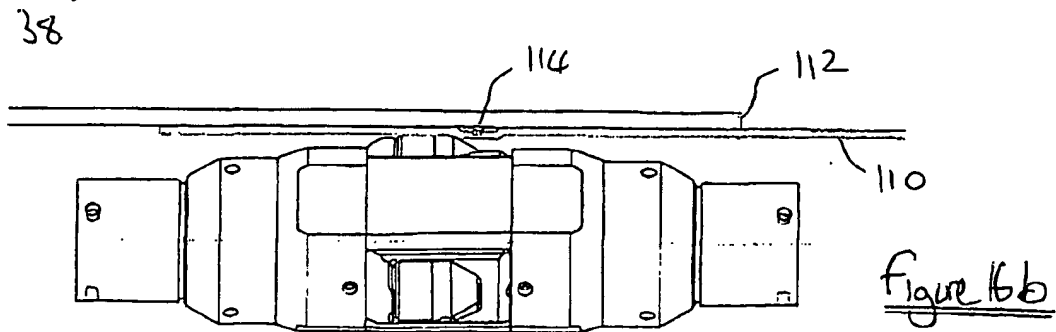

Figure 16b

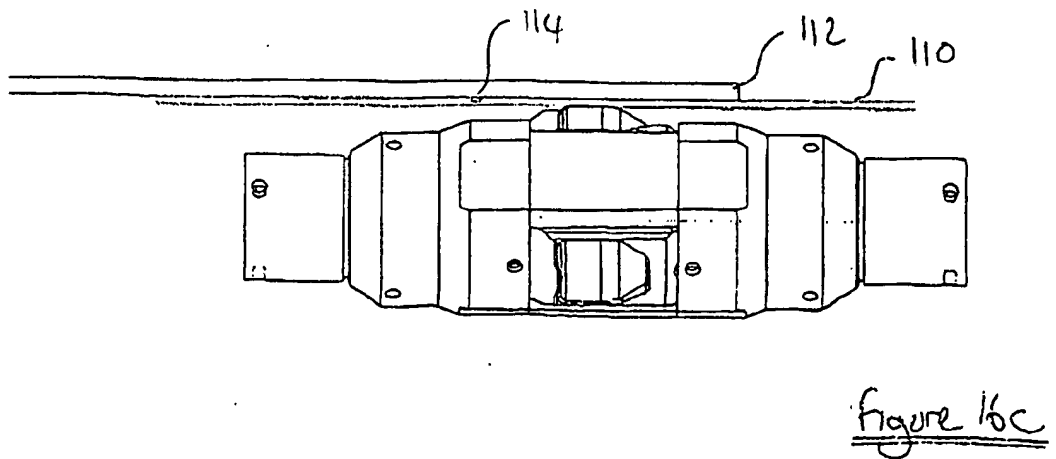

Figure 16c

SETTING SEQUENCE
RING SLIP IN BROAD GROOVE
(RESIDUAL GROOVING)

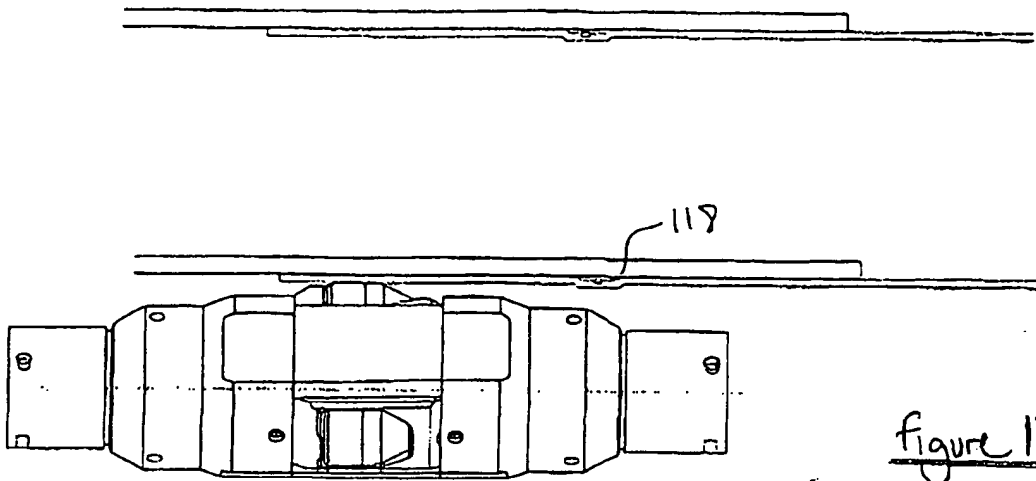

Figure 17a

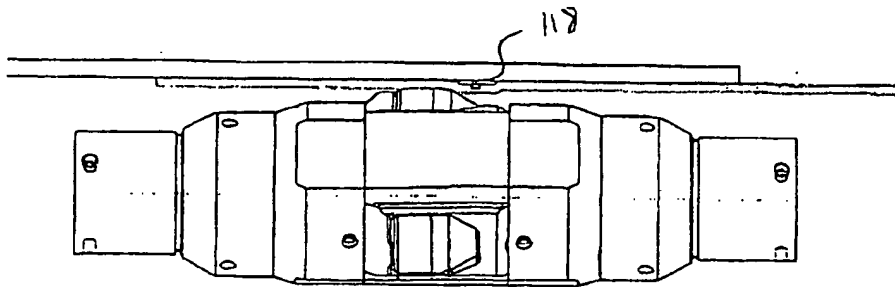

Figure 17b

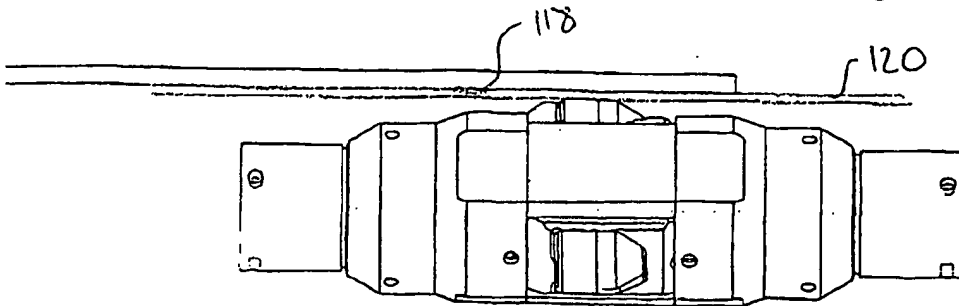
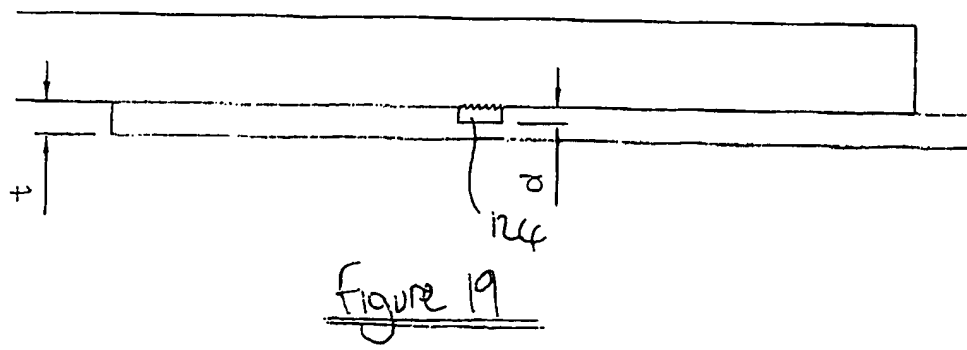
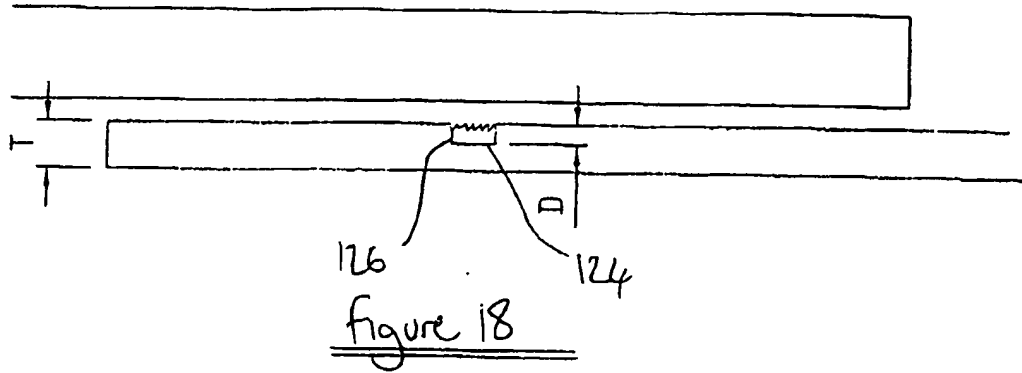
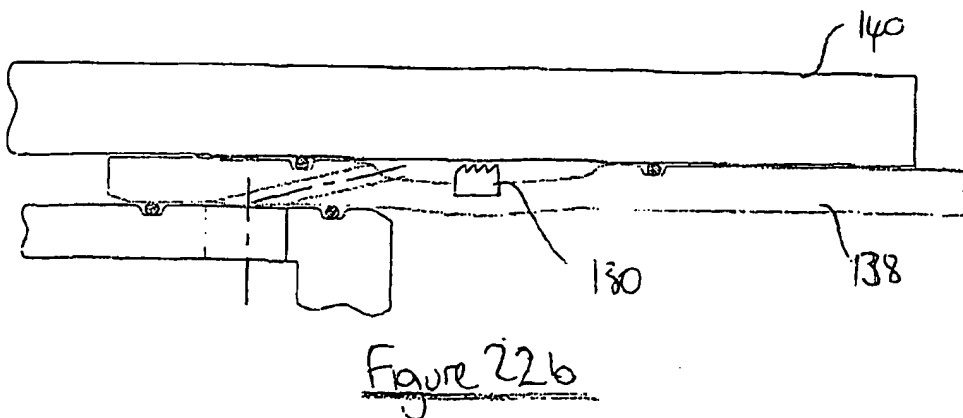
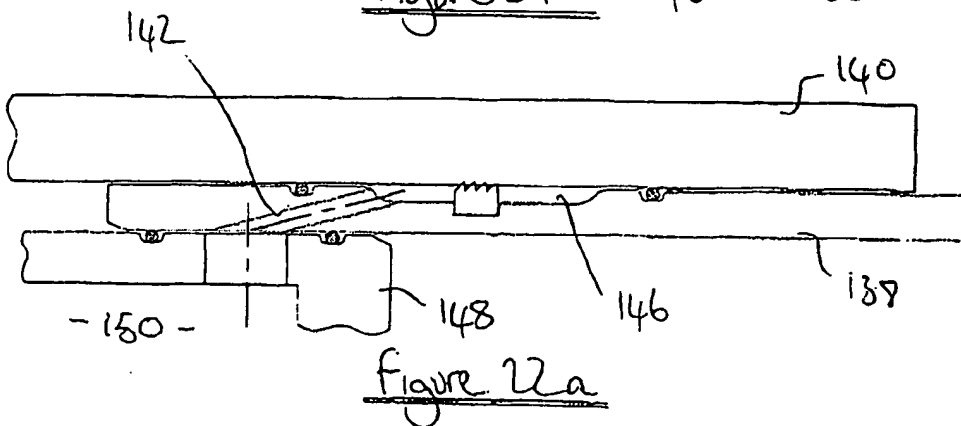
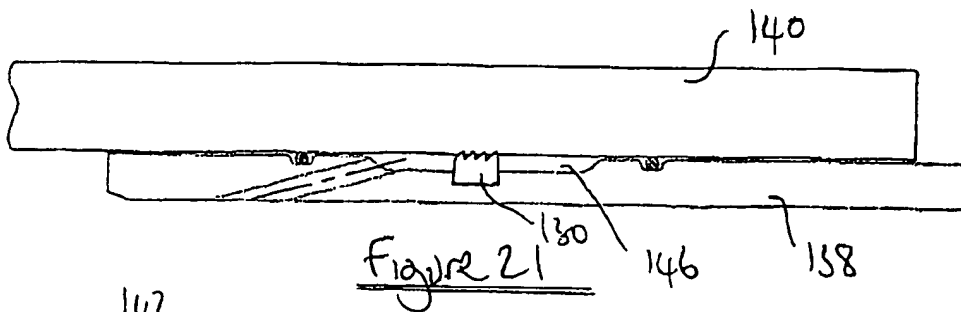
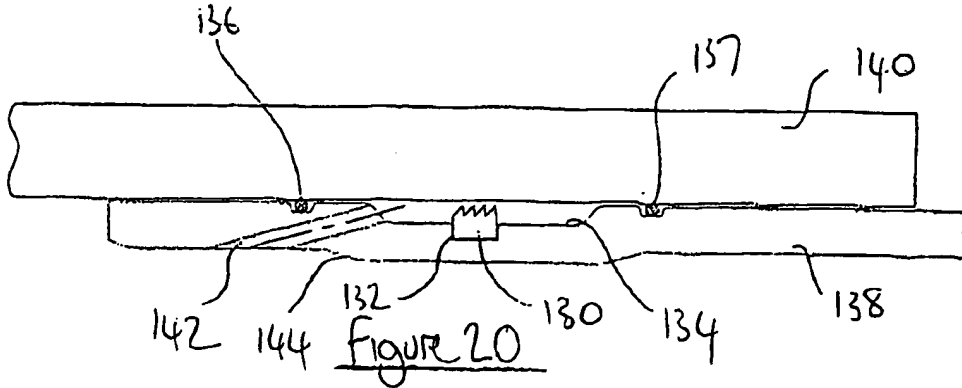

Figure 17c

RING SLIP IN NARROW GROOVE



RELEASING SYSTEM FOR RING SLIP IN BROAD GROOVE



- 150 -

RELEASABLE RING SLIP - PARALLEL

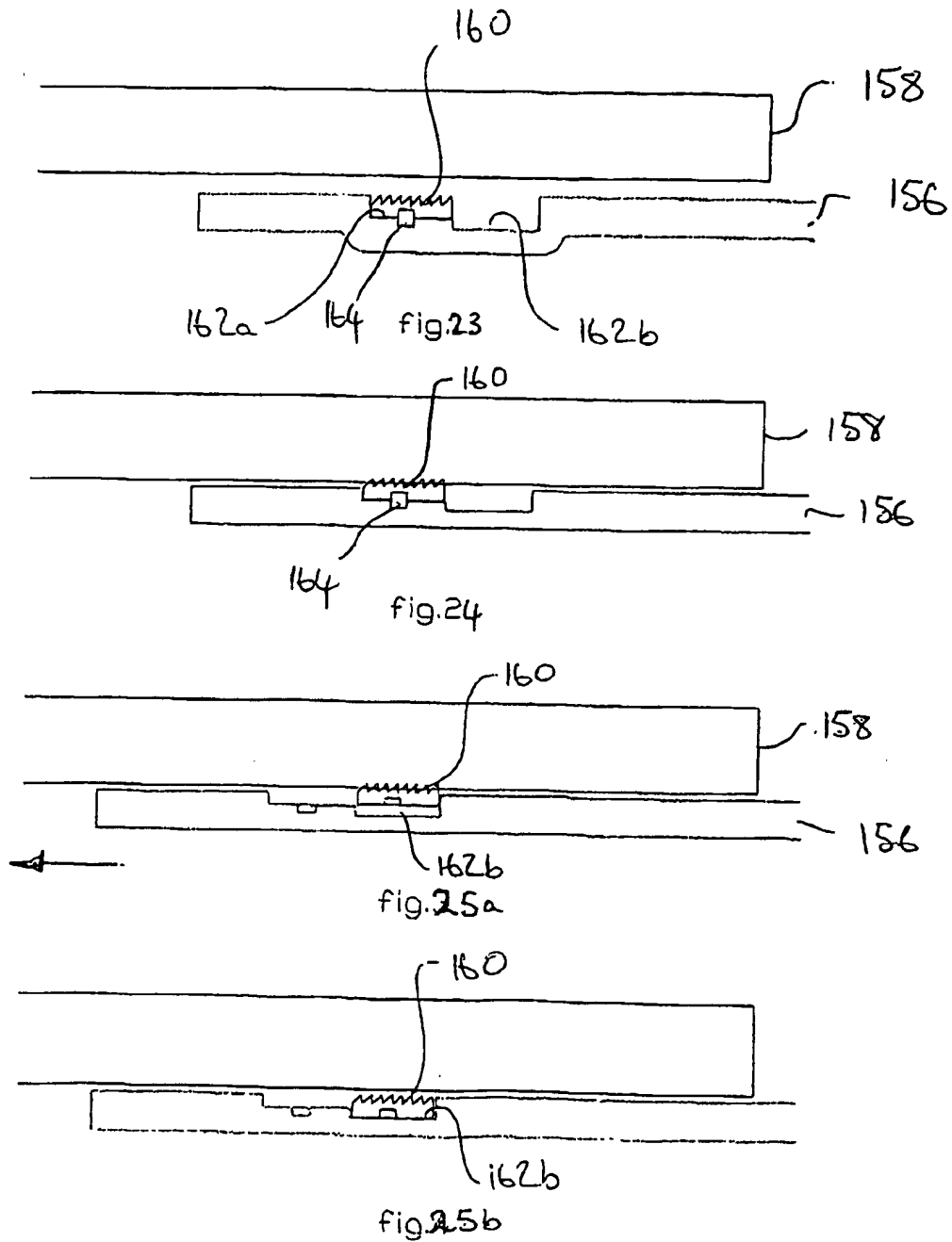

RELEASABLE RING SLIP - TAPERED

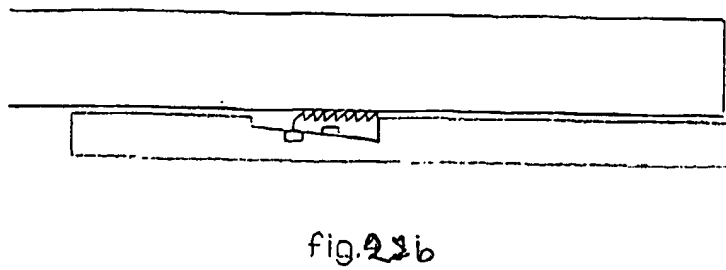
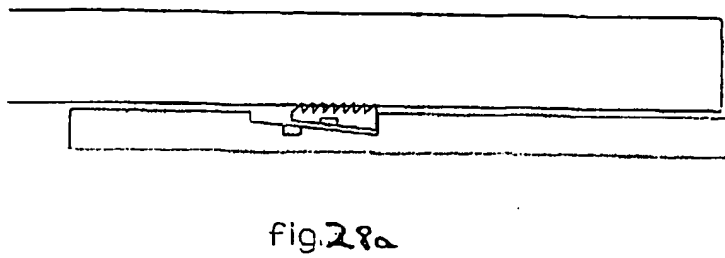
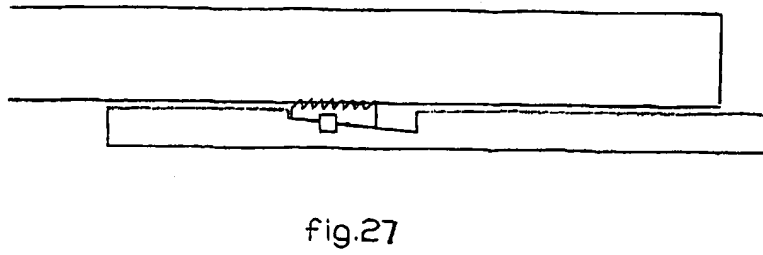
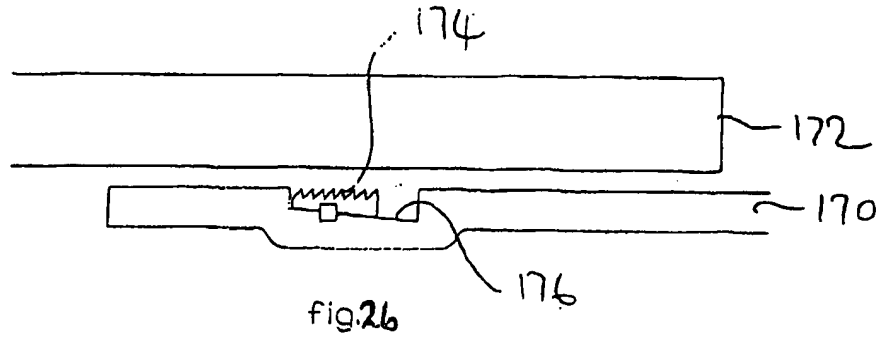

15/15
RECESSED SPOT FACE
HANGER SYSTEM

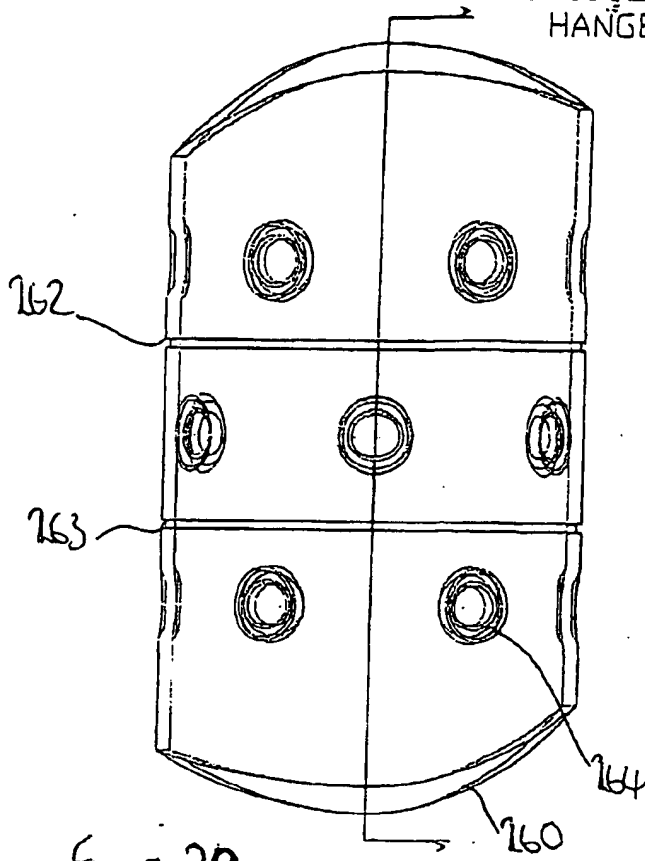
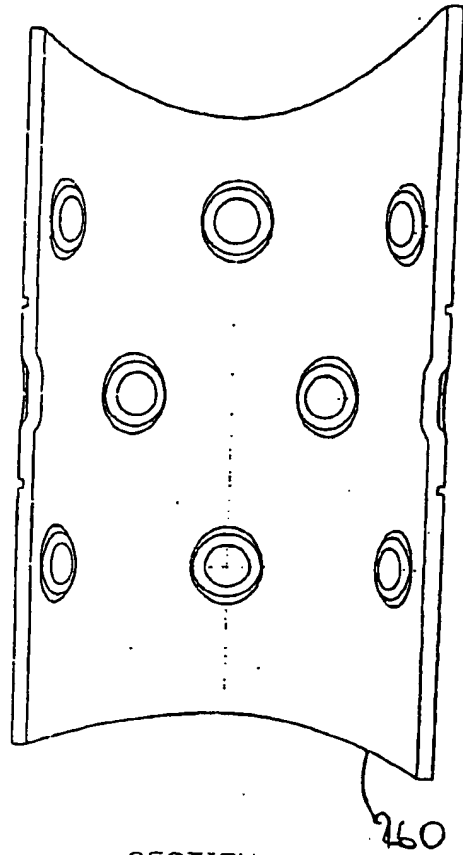

Figure 30



SECTION A-A

Figure 31

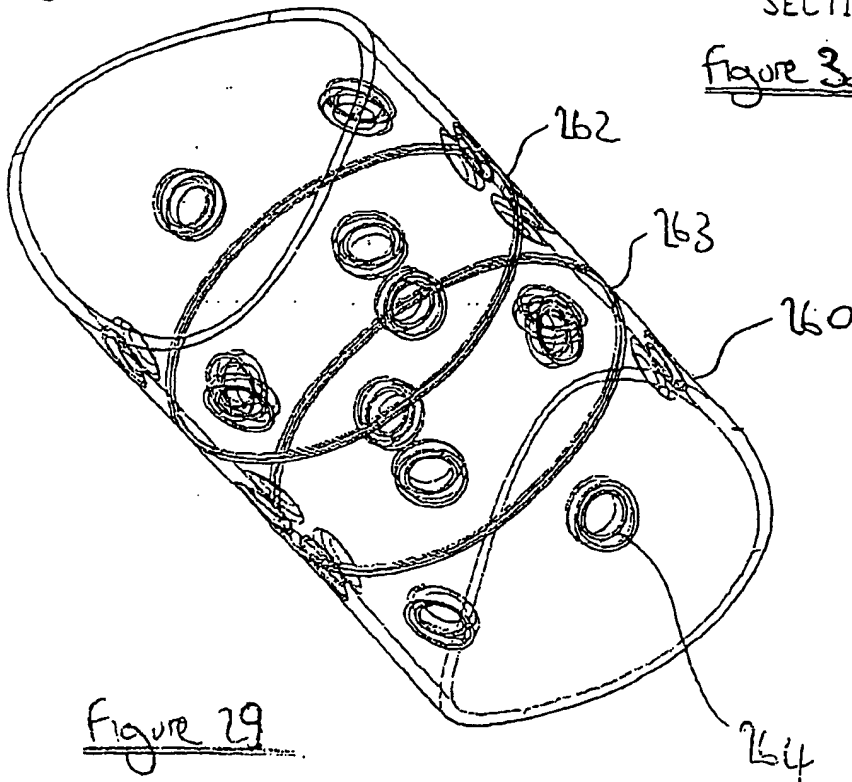

Figure 29

INTERNATIONAL SEARCH REPORT

International Application No

PCT/GB 02/01315

A. CLASSIFICATION OF SUBJECT MATTER
 IPC 7 E21B43/10 E21B41/00

According to International Patent Classification (IPC) or to both national classification and IPC

B. FIELDS SEARCHED

Minimum documentation searched (classification system followed by classification symbols)
 IPC 7 E21B

Documentation searched other than minimum documentation to the extent that such documents are included in the fields searched

Electronic data base consulted during the international search (name of data base and, where practical, search terms used)

EPO-Internal

C. DOCUMENTS CONSIDERED TO BE RELEVANT

Category*	Citation of document, with indication, where appropriate, of the relevant passages	Relevant to claim No.
X	US 6 189 616 B1 (GANO JOHN C ET AL) 20 February 2001 (2001-02-20)	1,2,4,5, 8-10, 12-15, 17,18, 20-22; 47-53; 55-60, 63-68, 71-73, 76,77
Y	column 13, line 37-53; figures 6A-10	3,6,7, 16,19, 23-29, 33, 35-46, 54,69,70
	---	-/--

Further documents are listed in the continuation of box C.

Patent family members are listed in annex.

* Special categories of cited documents:

- *A* document defining the general state of the art which is not considered to be of particular relevance
- *E* earlier document but published on or after the international filing date
- *L* document which may throw doubts on priority claim(s) or which is cited to establish the publication date of another citation or other special reason (as specified)
- *O* document referring to an oral disclosure, use, exhibition or other means
- *P* document published prior to the international filing date but later than the priority date claimed

- *T* later document published after the international filing date or priority date and not in conflict with the application but cited to understand the principle or theory underlying the invention
- *X* document of particular relevance; the claimed invention cannot be considered novel or cannot be considered to involve an inventive step when the document is taken alone
- *Y* document of particular relevance; the claimed invention cannot be considered to involve an inventive step when the document is combined with one or more other such documents, such combination being obvious to a person skilled in the art.
- *&* document member of the same patent family

Date of the actual completion of the international search

19 June 2002

Date of mailing of the international search report

28/06/2002

Name and mailing address of the ISA

European Patent Office, P.B. 5818 Patentlaan 2
 NL - 2280 HV Rijswijk
 Tel. (+31-70) 340-2040, Tx. 31 651 epo nl,
 Fax: (+31-70) 340-3016

Authorized officer

Ott, S

INTERNATIONAL SEARCH REPORT

International Application No

PCT/GB 02/01315

C.(Continuation) DOCUMENTS CONSIDERED TO BE RELEVANT

Category *	Citation of document, with indication, where appropriate, of the relevant passages	Relevant to claim No.
X	US 5 083 608 A (ABDRAKHMANOV GABDRASHIT S ET AL) 28 January 1992 (1992-01-28)	1,2,4,5, 8,9, 11-15, 17,18
Y	abstract; figures 1,2,7	31,32,34
Y	WO 01 18353 A (E2 TECH LTD ;INNES GARETH (GB); OOSTERLING PETER (NL)) 15 March 2001 (2001-03-15) page 4, line 16 - line 26; figure 3	3,6,16, 19, 23-29, 31-41, 43-46, 54,70
Y	US 5 494 106 A (GUEGUEN JEAN-MARIE ET AL) 27 February 1996 (1996-02-27) figure 3A	7
Y	GB 2 345 308 A (PETROLINE WELLSYSTEMS LTD ;ASTEC DEV LTD (GB)) 5 July 2000 (2000-07-05) figures 9,10	42,69
P,X	WO 01 33037 A (STEWART R BRUCE ;COOK ROBERT LANCE (US); COWAN KENNETH MICHAEL (US)) 10 May 2001 (2001-05-10) figure 4	1,14,23, 37

INTERNATIONAL SEARCH REPORT

Information on patent family members

International Application No

PCT/GB 02/01315

Patent document cited in search report	Publication date	Patent family member(s)	Publication date	
US 6189616	B1	20-02-2001	US 6135208 A EP 0961007 A2	24-10-2000 01-12-1999
US 5083608	A	28-01-1992	CA 2006931 C WO 9005833 A1 AU 623123 B2 AU 3188389 A EP 0397874 A1 DE 3855789 D1 JP 2710680 B2 JP 3502350 T NO 300987 B1	24-10-1995 31-05-1990 07-05-1992 12-06-1990 22-11-1990 20-03-1997 10-02-1998 30-05-1991 25-08-1997
WO 0118353	A	15-03-2001	AU 7020700 A EP 1210501 A1 WO 0118353 A1 NO 20021080 A	10-04-2001 05-06-2002 15-03-2001 19-03-2002
US 5494106	A	27-02-1996	FR 2717855 A1	29-09-1995
GB 2345308	A	05-07-2000	AU 1867900 A AU 1868700 A AU 1868800 A AU 1868900 A AU 1876600 A AU 1876800 A EP 1147287 A2 EP 1141517 A1 EP 1141515 A1 EP 1144802 A2 EP 1151180 A1 EP 1141518 A1 WO 0037766 A2 WO 0037771 A1 WO 0037768 A1 WO 0037767 A2 WO 0037772 A1 WO 0037773 A1 GB 2346632 A GB 2346400 A GB 2346909 A GB 2347445 A NO 20012596 A NO 20012597 A NO 20012598 A NO 20012599 A NO 20012600 A NO 20012865 A US 2002060079 A1	12-07-2000 12-07-2000 12-07-2000 12-07-2000 12-07-2000 12-07-2000 24-10-2001 10-10-2001 10-10-2001 17-10-2001 07-11-2001 10-10-2001 29-06-2000 29-06-2000 29-06-2000 29-06-2000 29-06-2000 29-06-2000 29-06-2000 16-08-2000 09-08-2000 23-08-2000 06-09-2000 27-07-2001 27-07-2001 30-07-2001 30-07-2001 30-07-2001 07-08-2001 23-05-2002
WO 0133037	A	10-05-2001	AU 1356601 A WO 0133037 A1	14-05-2001 10-05-2001